

* A VERSATILE UNIT ACCEPTING 455kHz TO SUIT MOST RECEIVERS

* USER CONTROLS:

- | | | |
|---------------------------|-------------|-------------------------------|
| <u>AUDIO</u> | <u>LOOP</u> | <u>WINDOW</u> |
| [LOW DISTORTION ENVELOPE | [WIDE | [OFF / ON |
| [DSB | [MEDIUM | |
| [LSB | [NARROW | |
| [USB | | [CENTRE FREQUENCY \pm 4kHz |
| [ISB / STEREO SPREAD | | |
| [QUADRATURE | | |

Synchronous detection of am signals has long been known to provide several benefits but practical systems for radio reception have often been disappointing, though the technique has been applied to demodulation of vestigial sideband television for many years. Several of the problems for synchronous radio reception, particularly in the case of short wave, arise from the need to cater for very poor signal to noise or interference ratios. To avoid the generation of objectionable heterodynes the phase lock loop used to produce the synchronous carrier for demodulation must maintain lock down to negative signal to noise ratios and not suffer phase modulation in the presence of the following:

- * Reduced carrier operation, as proposed for future hf broadcasting
- * Fading of signal and sidebands
- * Selective fading of carrier and sidebands
- * Reception of transmissions utilising either type of dynamic carrier control: increasing or decreasing with audio level
- * Interfering signals of any description and any strength more than about 30Hz from the wanted carrier.

Conversely, the loop may need to follow accurately phase modulation on the received signal in the following circumstances:

- * Various phase modulated radio data systems on lf and mf broadcasts
- * Spurious hum, synthesiser noise or poor frequency stability on transmissions
- * Spurious phase modulation by the wanted audio.

These characteristics are technically equivalent to unfiltered exhalted carrier, or 'synchrodyne', reception, where the received signal is limited to provide a carrier which is itself used directly for synchronous demodulation. Finally, if the transmission ceases the loop should remain very close to its last frequency indefinitely and reacquire lock within a few milliseconds of the signal reappearing.

Where there is selective fading, or where single sideband reception is selected, the need for the demodulating carrier to be accurately in phase with the received carrier can be abandoned since wanted sideband energy exists both in phase and in quadrature with any demodulating carrier. It would be undesirable to attempt to follow the rapid polarity inversion of a carrier which has experienced a selective fade, so the flywheeling action of frequency lock only is required.

Apart from the gross distortion which arises in an envelope detector during a selective fade of the carrier, which is overcome by synchronous detection, there is also an objectionable surging in the audio level caused by the receiver agc system unnecessarily increasing the gain. This effect can be ameliorated by an audio gain control system which senses the peak level of the selected audio output and reduces the gain appropriately.

MANUFACTURING ALIGNMENT

Set input preset, R1 to maximum (clockwise). Inject -24dBm ('-30dBm' if unterminated). Meter TP Z reference TP Y and adjust L2 for OV when loop locked to 455kHz.

Switch to QUADRATURE, WINDOW ON: NARROW Adjust CENTRE FREQUENCY] to null
WIDE Adjust R25] modulation.
Repeat.

Using a hybrid also inject 456kHz. Adjust R73 for a null in heterodyne; LSB.
Inject 454kHz. Adjust R69 for a null in heterodyne; USB.

With 100% modulation check all audio levels match within 0.5dB.

Increase rf input and check operation of audio limiter for outputs beyond +0.5dBu.

INSTALLATION ALIGNMENT

With 455kHz fed from the desired receiver, tune to a strong broadcast station and adjust R1 so that a 100% modulated, non-fading, am signal does not quite activate the audio limiter. Either monitor TP X reference TP Y with a ground free scope or high impedance dc meter OR monitor the peak audio output and short TP X to TP Y, to disable limiting and reveal whether it is being activated.

The board has a high input impedance and can often be fed, with dc blocking, from around the final if can; a tap point or secondary often giving a lower impedance feed. If too much damping results or if a long cable needs to be fed an emitter follower buffer can be used.

COMPONENT LIST

3	47	2	220k	1	470n 5%
2	680	4	330k 1%	1	1μ 5%
1	1k	1	470k 1%	4	1μ tant
2	1k5	2	820k 1%	1	10μ tant
5	2k2	9	1M 1%	3	33μ tant
1	2k4 1%			3	47μ ali
1	3k 1%	1	2k cerm	2	100μ tant
3	3k3 1%	1	22k cerm	1	100μ 6V ali
2	4k7	1	47k cerm		
3	6k8	1	220k cerm	1	4718 TR1
4	8k2 1%	1	100k pot	1	5868 L2
1	9k1 1%			1	10mH L1
10	10k 1%	5	4p7		
1	15k	2	10p	3	0A90
1	16k 1%	2	22p	6	1N4148
4	27k 1%	5	47p	1	1N4001
1	33k	2	330p	1	3V3
1	43k	1	470p	1	BE409G
3	47k 1%	2	1n CD	1	40822/3, 3N201
8	56k 1%	2	4n7 5%	1	BC309
2	82k	2	12n 5%	2	BC549
10	100k 1%	1	47n	1	2N2369
1	150k	13	100n 5%		

Suggested if buffer

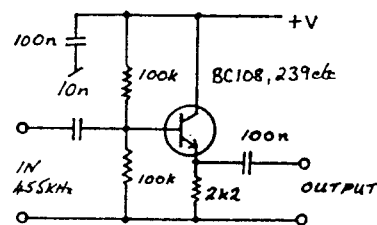

1	7805
1	4013
1	44066
3	TL084
2	2p6w 327-608
2	Maka 327-311
	tag bottom, 2
	+5th hole stops
7	DIL 14 skts
15	vero pins

LISTENING NOTES A lot of the energy in ionospheric cross-modulation is in quadrature. In southern England try 254kHz Algeria by 162kHz France or 594kHz and 1593kHz Germany by 64.8kHz BBC Orfordness as good examples. The s/n improvement in DSB is particularly evident on sideband splatter and weak signals through rejection of energy in quadrature and all audio noise, produced by envelope detectors, above half the if bandwidth disappears. An incidental benefit of the limiter is improved listenability of signals suffering severe lightning static or electrical interference. Nightly USB tx: 526.5kHz Vatican.

CIRCUIT DESCRIPTION

4.55kHz if enters via the input control which allows the gain to be set to suit the level coming from the receiver, so that a 100% modulated signal with full carrier does not quite activate the audio limiter. T1 provides buffering and amplification with an output tuned circuit to reject harmonics of 4.55kHz. IC1 forms a high performance limiter with low am to pm conversion and good limiting action down to very low input levels. The squared output feeds the balanced demodulator formed by IC7C,D and IC3B. A preset allows offsets to be cancelled so that the regenerated carrier is accurately in phase.

IC3C, with IC7A and IC7B, forms the main loop filter and can be switched between three different bandwidth characteristics. WIDE allows the loop to lock quickly over a range of ± 6 kHz and can be used for general tuning around. MEDIUM restricts the rapid locking range to ± 1 kHz, which is about as narrow as one can go when receiving pm data systems (France 162kHz, East Germany 177kHz, U.K. 198kHz, West Germany 1017kHz). The presence of phase modulation on an am signal unavoidably leads to further degradation of reception in the presence of selective fading or co-channel interference. NARROW brings the bandwidth down to ± 30 Hz, which is low enough to avoid disruption by audio components yet still allow some margin for receiver drift. This position gives a flywheeling effect so that the regenerated carrier will not attempt to follow the rapid phase changes and polarity inversions of a signal suffering selective fading or cancellation fading, where two stations are nearly on the same frequency.

The WINDOW selector switch restricts the voltage swing which can be fed out to the varicap and thus prevents the loop being captured by signals away from the desired frequency set by the CENTRE FREQUENCY control. This facility means that the receiver if filters can be exploited to the maximum advantage, in addition to the sideband selection on the unit. For instance, the receiver if filter could be positioned entirely over one sideband of an am signal, the appropriate sideband selected on the unit and CENTRE FREQUENCY offset to where the carrier now lies. The WINDOW facility allows the loop to hold lock tenaciously even when the wanted carrier is down the slope of the if filter or buried beneath noise and interference. In the absence of any steady carrier within 30Hz, the loop will generate a carrier stable enough to permit reception of cw, fsk or suppressed carrier ssb signals.

The output from the loop amplifier is fed to the varicap which controls the frequency of the Colpitts oscillator formed by T4 at 1820kHz. T5 is a high slew rate amplifier feeding the $\pi/4$ circuit, IC6, which produces in-phase and quadrature feeds of both polarities at 4.55kHz to drive the three balanced demodulators.

4.55kHz if from T1 passes through an emitter follower buffer T2 and then to the in-phase demodulator, IC2A,B and IC3D, the quadrature demodulator, IC2C,D and IC5B and the low distortion envelope detector, T3 driving D1 with constant current. IC3A amplifies the output from the envelope detector while IC4B and IC5A respectively invert and reduce the amplitude of the in-phase and quadrature demodulator outputs and provide drive for the broadband audio phase shift networks. The outputs from these networks are summed by IC5D for USB and differenced by IC5C for LSB.

SW1A and B select the outputs desired. ENVELOPE can be convenient for general tuning to exploit the receiver filters fully when a signal is suffering interference before going into synchronous modes. DSB gives reduced distortion on heavily modulated and on over-modulated signals

arising from selective fading of the carrier. Next come LSB and USB followed by ISB / STEREO SPREAD with LSB on the left and USB on the right. This gives interesting effects on fading signals and when two sidebands are suffering different interference. An unexpected observation has been that lightning static at lf and mf often sounds quite different in the two sidebands. Finally, QUADRATURE gives a null on the audio from the strongest station on the channel, thus improving the audibility of any background station. This position can also be used to receive nbfm, or any other phase modulation.

IC4C and D form a full wave peak rectifier which senses the peak audio output level beyond a threshold of +0.5dBu, giving a small guard band beyond the 0dBu output for a full carrier 100% modulated signal. IC4A provides amplification and drives the storage capacitors through a resistor chosen to give an attack time of a few milliseconds. The double time constant arrangement allows a short burst of audio beyond the threshold to reduce the gain for only a short time while longer lasting high levels will cause a slower release time to operate. These characteristics avoid impulsive interference or programme material causing unpleasant pumping effects. The dc output from the time constants is fed to T1, where it controls the 455kHz input amplifier gain.

The unit requires a positive supply between 10 and 16V at 50mA and IC8 generates an internal 5V regulated line. A suitable supply can often be obtained from the receiver the unit is used with. The audio outputs may be fed into any stereo system, or just the Left output used with a mono amplifier, or fed back into the receiver's own amplifier and loudspeaker. Obviously great benefits are to be had from the use of good loudspeakers.

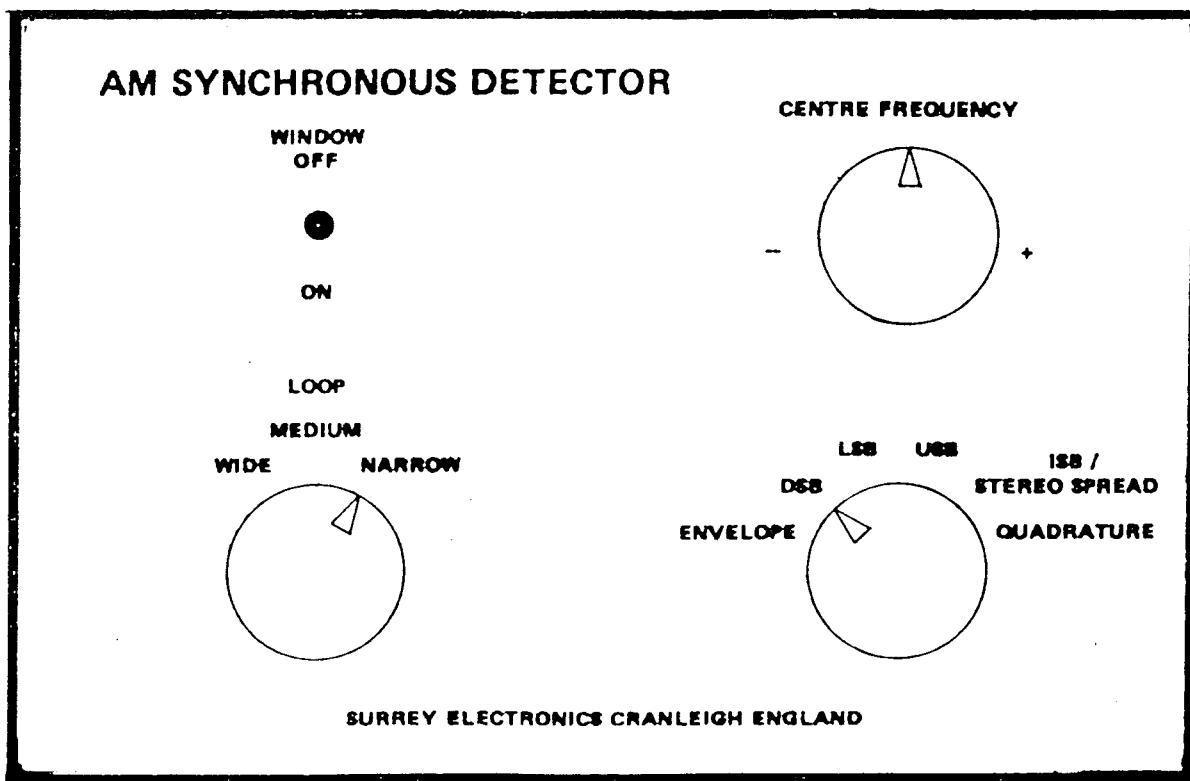

Sold for Radiofax with all profits contributing to operating costs. Complete boxed unit : £150. UK post and packing free, add 15% VAT. Europe air mail add £12. Rest of the world air mail add £16. Payment before despatch.

SURREY ELECTRONICS
 Limited
 THE FORGE · LUCKS GREEN
 CRANLEIGH
 SURREY GU6 7BG
 ENGLAND
 Tel: 0483 275997

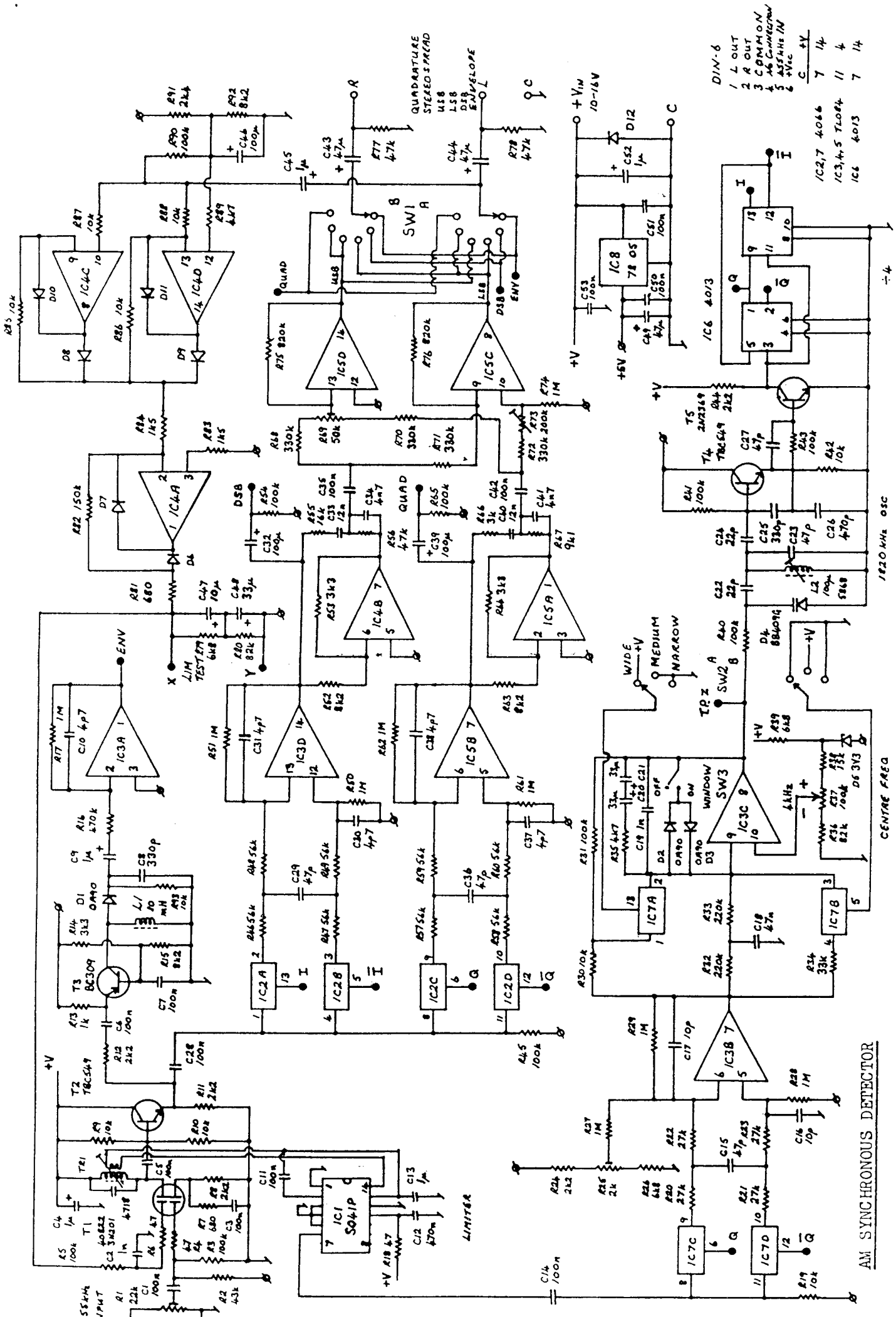

- DIM-6
- 1 L OUT
 - 2 R OUT
 - 3 COMMON
 - 4 +6V COMMON
 - 5 +5V IN
 - 6 +Vcc

C	+V
7	14
IC2,7	4066
IC3,4,5	TL084
IC6	4013
7	14
14	14

AM SYNCHRONOUS DETECTOR

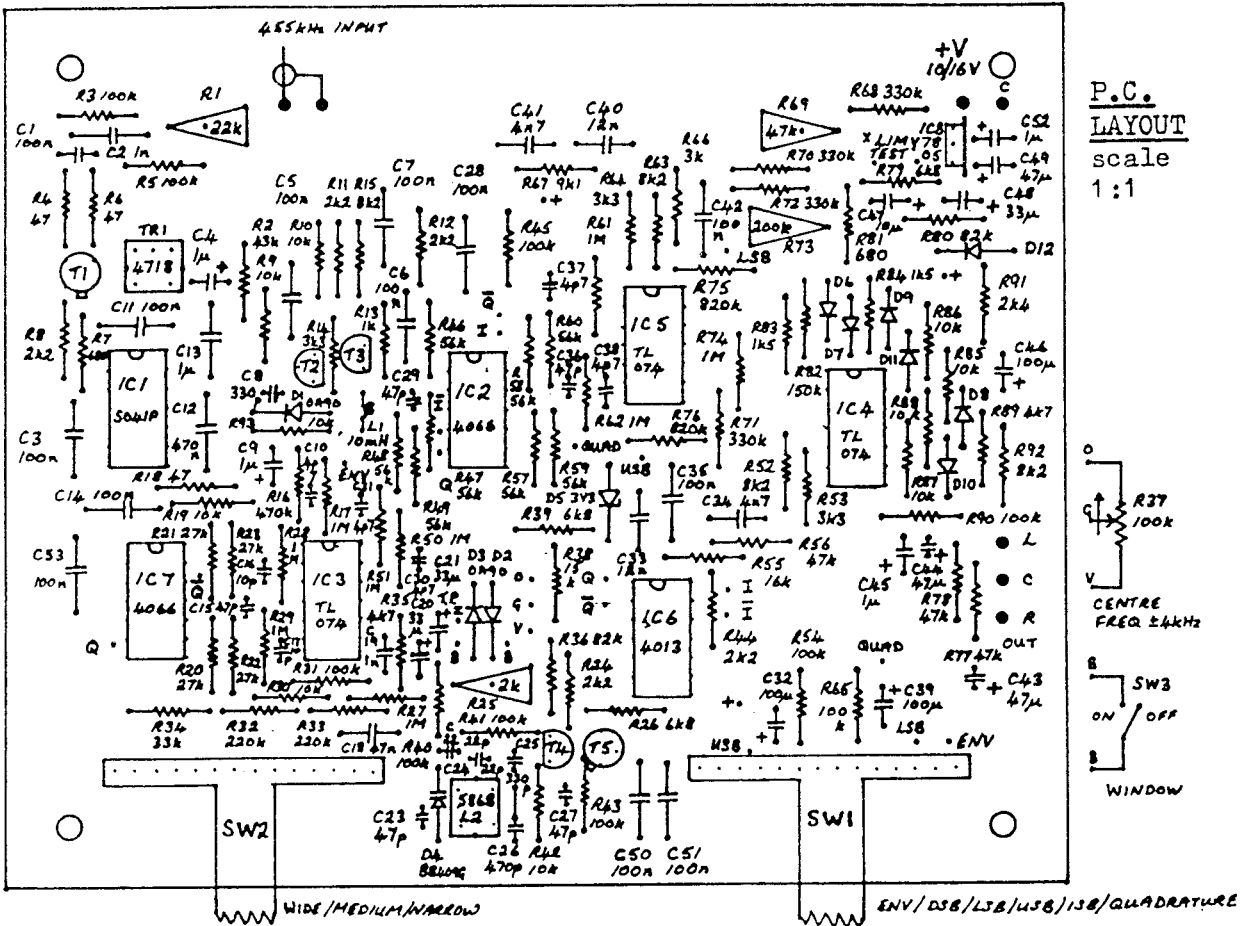

DIN 6:pin connections

- 1 Left output
- 2 Right output
- 3 COMMON
- 4 No connection
- 5 455kHz input
- 6 +10/16 volts

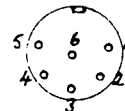

View looking at panel socket

Other IF Frequencies

It is practicable to align this unit for if frequencies between 445 and 465kHz but for other ifs the input must be converted to 455kHz with the aid of a mixer and (preferably) crystal oscillator.

NOTES

On some receivers a clipping effect can occur when receiving a strong signal. If the signal carrier selectively fades out the receiver can increase the gain so much that the modulation sidebands drive into momentary overload of the last if stages.

To overcome this problem increase the agc threshold, to limit the amount of gain the receiver can utilise, or, failing such a control, reduce the if or rf gain.